

# Tilth Worm Composting Bin

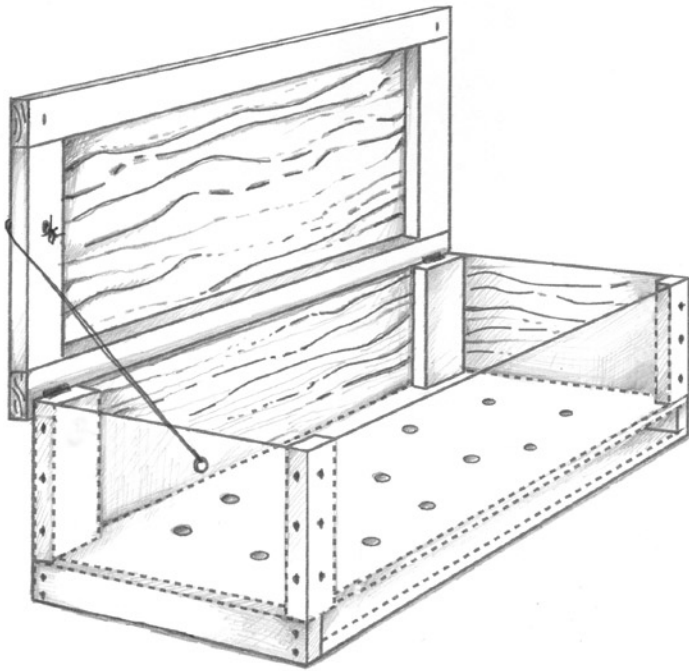

## This system is designed for composting fruit and vegetable food scraps using red worms, a process called *vermicomposting*.

Food scraps and worms are “bedded” in moist brown leaves, shredded newspaper, cardboard, or clean wood shavings. The red worms turn both the food scraps and bedding into high-quality compost suitable for use on houseplants, seedlings or general garden use.

To maintain this system, simply rotate burial of food scraps throughout the fully bedded bin. To bury your food scraps, dig a hole in the bedding, put in food scraps and then cover completely with clean bedding. A properly maintained worm bin should be odorless. Flies may be controlled and moisture maintained by placing a sheet of plastic or cardboard on top of the bedding.

Every 9 to 12 months, the partially finished compost and/or bedding should be moved to one side of the bin, left to age, and new bedding added to the empty half of the bin. Start burying food scraps only in the new bedding. Within four to six weeks, worms will move from the aging compost and populate the new bedding. The finished compost may now be harvested and the open space in the bin can be rebedded. Any large uncomposted food scraps can be added back into the bin.

Worm bins can be kept outside, or in a cool indoor space such as a basement or garage. Outdoor worm bins should be located in a shady protected area. To keep your worms from freezing in winter keep your bin fully bedded. Worm bins can also be insulated with bags of leaves or straw bales laid around and on top of the bin. Another option is solid core blue foam insulation which can be secured to the top and sides of the bin with duct tape and removed in spring or summer.

This bin can be built for about \$30 to \$50, depending on the type of wood\* used. (Do not use treated wood of any kind.) The exterior of the bin may be painted with a good quality latex primer and latex finish coat. Worm bins can also be made from recycled materials, wooden boxes, or other containers. All worm bins must have drainage holes in the bottom to drain excess liquid and a tight fitting lid to keep moisture in and pests out.

A starter batch of worms can be purchased at a small additional cost, or obtained from a friend’s bin, or found in an old compost pile. Call The Garden Hotline at 206.633.0224 for sources of red worms and to request the *Composting at Home* and *Building Healthy Soil* guides.



The Natural Soil Building Program is sponsored by Seattle Public Utilities and managed by the Seattle Tilth Association.

This recycled paper is recyclable. Revised 12/03

Seattle  
Public  
Utilities

\*Wood products that have the FSC logo give “the consumer a guarantee that the product has come from a forest which has been evaluated and certified as being managed according to agreed social, economic and environmental standards.”



## Construction Details

---

Familiarize yourself with the cutting sequence and expanded view. Make sure to use pencil and straight edge to mark all measurements before cutting.

Careful cutting is essential to get all the pieces to fit properly. Cutting can often be done for an extra charge (25 to 50 cents per cut), at lumber stores with advance notice.

Start by cutting the sheet of plywood in half. When making this first cut (#1), just barely leave the 48" pencil line. Next, take the full 48" x 48" piece and divide it into three equal pieces (cuts #2 and #3). This time, split the pencil line with the cut, otherwise the pieces will end up being too small because the saw blade takes  $\frac{1}{8}$ " every time a cut is made. Splitting the pencil line again, divide one of the three pieces just cut in half (cut #4). These four pieces will become the front side, back side and two ends. Cut the other half of the sheet as per the drawing (cut #5). Split the pencil line on the 23" cut. This will be part of the bottom. The remaining piece will be part of the lid and the dimensions of this piece are not critical.

The bin can be divided into three parts: bottom, sides, and the lid. Start by constructing the bottom.

**Bottom** Cut one of the 2x2s into two 48" sections. From the other 2x2, cut two pieces 20" long. Attach these pieces to the edges of the bottom. Cut one more piece of 2x2, 20" long for the middle support on the bottom. Use only a few deck screws per side. Next, drill  $\frac{3}{8}$ " drainage holes in the bottom. See expanded view for one pattern for these holes. Need 12 to 16 holes.

**Sides** Cut from one of the 2x4s two pieces 14 $\frac{1}{4}$ ". Cut from one of the 2x2s two pieces 14 $\frac{1}{4}$ ". These four pieces are the corner blocks. Next, place the 2x2s under each end of what will become the front. Look for the best plywood surface to be up as that will show on the final bin. Make sure the ends of the 2x2s are flush with the top edge of this front side. Fasten using the deck screws. Follow the spacing pattern shown on the expanded view. Do the same with the other side using the previously cut 2x4s. This side will be the back of the bin. Attach the ends to the just completed front and back sides. Turn the completed unit so the bottom-end is facing up. Slide the bottom—plywood face down—into place so that it rests on the ends of the corner blocks. The bottom 2x2 framing will extend beyond the bottom

edge of the box. This is done to keep the plywood edges from direct contact with the ground. Fasten the sides and ends to the bottom using the screw pattern from the expanded view. Screws are used to assemble the bin because they are easier than nailing and mistakes can be corrected more easily.

**Lid** Cut two pieces of 2x4 51" long and two 18 $\frac{1}{2}$ " long. Lay the pieces out to form a rectangle. Center the plywood (best surface up) on this rectangle of 2x4s and fasten as per expanded view, the 2x4s will extend beyond the plywood. Next, attach the hinges to the back edge of the bin centered on the 2x4 corner blocks. Once this is done, place the lid on the bin, center it from side to side, and attach the hinges to the back edge of the top. Then, drill a  $\frac{3}{8}$ " hole in one end 4" from the front edge of the bin and down 3" from the top edge of the bin. Mark the lid directly above this hole and drill a  $\frac{3}{8}$ " hole through just the 2x4 edge of the top. Knot one end of the polypropylene rope; thread it through the hole in the bin leaving the knot on the inside of the bin. Then thread the rope up through the hole in the rim of the lid. Open the lid to just past vertical and tie another knot in the rope. This rope prevents the top from falling back and possibly breaking off the hinges. This completes the building of the worm bin.

---

### More on Natural Yard Care:

To receive the Naturals Guides: *Composting at Home*, or *Building Healthy Soil* or for more information on composting please call The Garden Hotline at 206-633-0224 or email them at [help@gardenhotline.org](mailto:help@gardenhotline.org).

### More resources can also be viewed at these websites:

[www.seattle.gov/util/Services/Yard/Composting/index.asp](http://www.seattle.gov/util/Services/Yard/Composting/index.asp)  
[www.savingwater.org](http://www.savingwater.org)  
[www.compostwashington.org/](http://www.compostwashington.org/)

### This and other compost bin plans can be found at:

[www.seattleilth.org/learn/resources-1/compost/compost-your.kingcounty.gov/solidwaste/garbage-recycling/documents/ez-wormbin\\_guide.pdf](http://www.seattleilth.org/learn/resources-1/compost/compost-your.kingcounty.gov/solidwaste/garbage-recycling/documents/ez-wormbin_guide.pdf)

Thank you to John Watson, a Master Composter/Soil Builder Volunteer, for revising the worm bin plans.

## Cutting Diagram

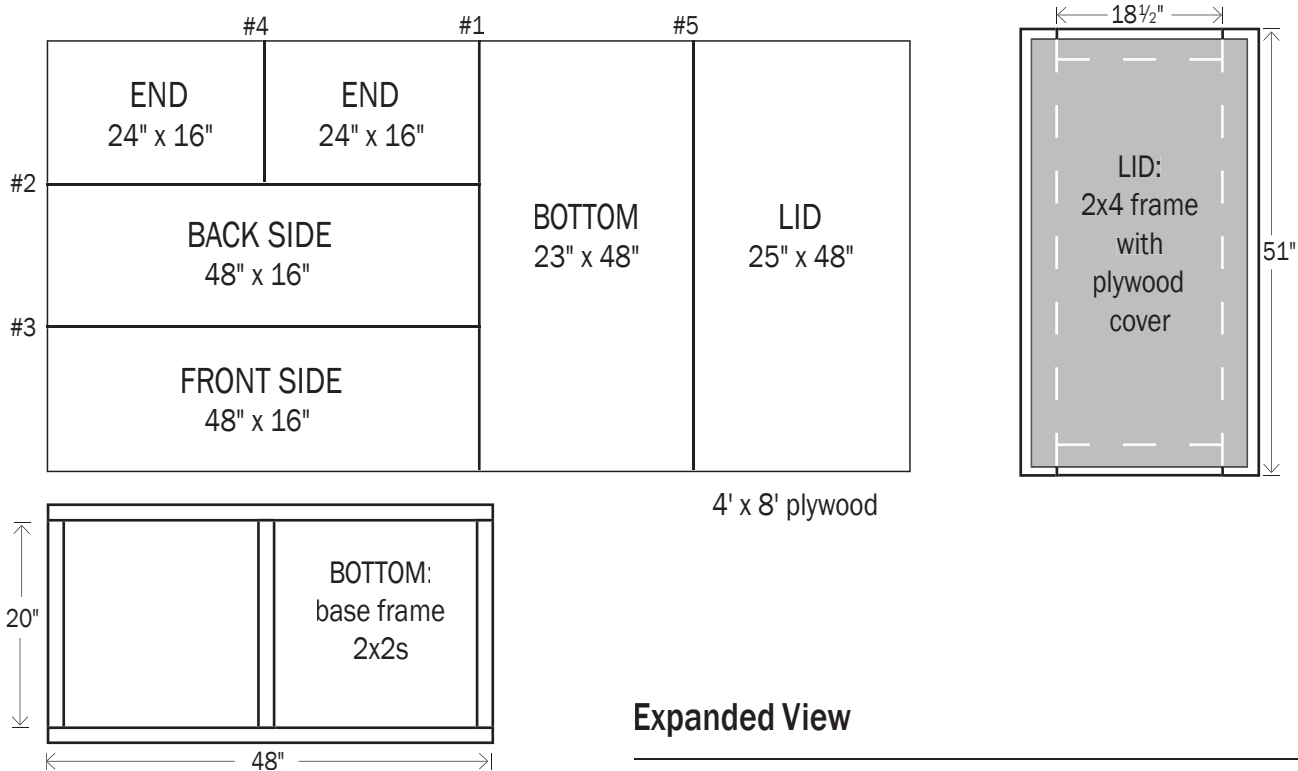

## Expanded View

### Materials\*

- 1 sheet of  $\frac{1}{2}$ " exterior plywood (CDX grade least expensive— ACX most expensive. Do not use composite or chip boards. They will not withstand the moisture generated in a worm bin)
- 2 8' 2x4s, (stud grade will probably be the straightest)
- 2 8' 2x2s, (common & better)
- 80  $1\frac{3}{8}$ " x #8 coated deck screws
- 1 pair of zinc plated 3" x 2" butt hinges without screws if possible (use the deck screws)
- 1 48" length of  $\frac{3}{8}$ " polypropylene rope

### Tools

Tape measure, portable electric saw or hand crosscut saw, electric drill with variable speed, #2 Philips driver bit,  $\frac{3}{8}$ " drill bit, hammer, pencil, 4' straight edge, pair of saw horses (for cutting plywood and assembling the bin) and eye and ear protective

Drills and saws can be rented if you have no real need to own power tools.

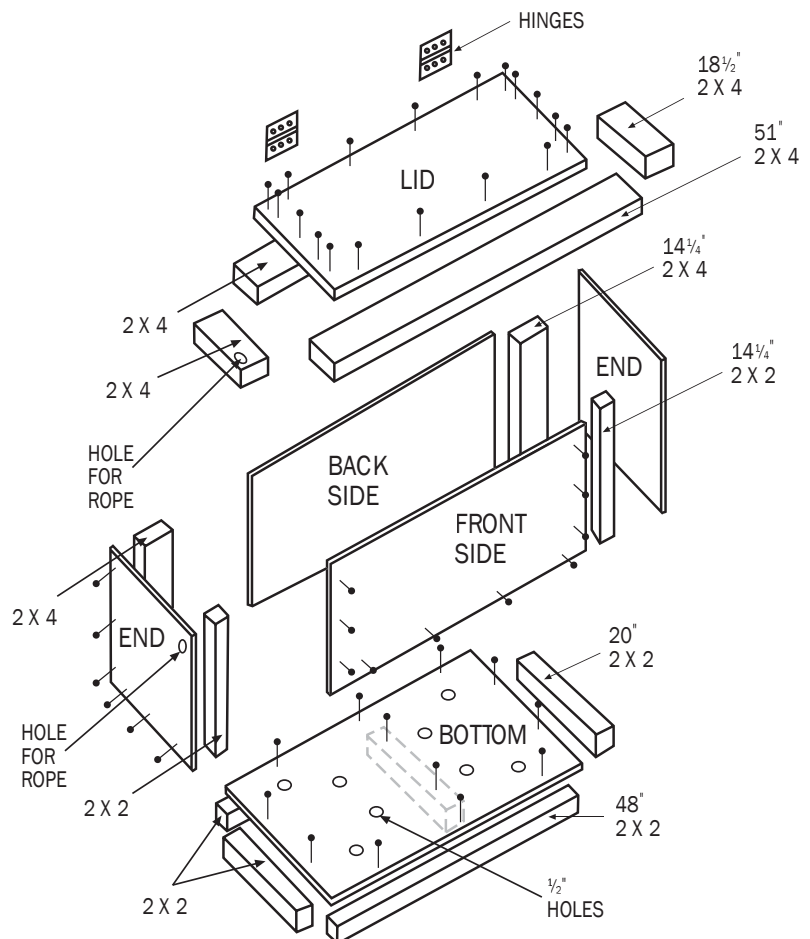

# Compost Websites

## General Composting

### Seattle Tilth Association

A fantastic organization that teaches people to garden organically, conserve natural resources and support local food systems. Download instructions for yard waste and food waste compost bins.

[www.seattle.tilth.org](http://www.seattle.tilth.org)

### Composting at Home

The City of Seattle Website addresses food and yard waste composting. Suggested reading, links, and sources for raw materials, chippers, bins, and worms.

[www.seattle.gov/util/Services/Yard/Composting/index.asp](http://www.seattle.gov/util/Services/Yard/Composting/index.asp)

### Seattle Public Utilities

Information on composting, water conservation, natural lawn care and gardening, recycling, waste reduction, green cleaning and watersheds.

[www.seattle.gov/util/Directory/Conservation\\_Index/index.asp](http://www.seattle.gov/util/Directory/Conservation_Index/index.asp)

### City Farmer, Canada's Office of Urban Agriculture

Scroll down to see a vast array of information and articles on composting and gardening.

[www.cityfarmer.org](http://www.cityfarmer.org)

### Washington Organic Recycling Council

Looks at the relationships between organics, recycling, soil, water, and salmon. Helpful links.

[www.compostwashington.org/](http://www.compostwashington.org/)

### Organic Gardening Magazine

Site contains rotating articles, soil and compost information, and books for sale.

[www.organicgardening.com/](http://www.organicgardening.com/)

## Sources for Buying Worms

### BRR Worm Farm, Little Rock, WA

Products and information on vermicomposting.  
[www.wormswrangler.com/index.htm](http://www.wormswrangler.com/index.htm)

### Yelm Earthworms & Casting Farm

Good site for buying worms, castings, soil, books, videos, and bins. Articles too.

[www.yelmworms.com](http://www.yelmworms.com)

## Sources for Bins, Bin Plans, & Materials

### Composters.com

Great pictures of all types of bins as well as products for lawn and garden care, pet waste management, recycling, and water conservation.

[www.composters.com](http://www.composters.com)

### Digitalseed website

Home composting information and easy-to-read instructions for homemade yard waste and food waste bins.

[www.digitalseed.com/composter/index.html](http://www.digitalseed.com/composter/index.html)

### King County Hazardous Waste

Lists resources for Manure, wood shavings, and building materials, for home composting.

[www.metrokc.gov/hazwaste/imex/toc.html](http://www.metrokc.gov/hazwaste/imex/toc.html)

### Spokane Regional Solid Waste System

Home composting information and yard waste bin plans.

[www.solidwaste.org](http://www.solidwaste.org)

### Urban Garden Center

Composters, worm bins, chippers, rain barrels and other yard and garden products for sale.

[www.urbangardencenter.com](http://www.urbangardencenter.com)